POWER QUALITY

Edited by **Andreas Eberhard**

INTECHWEB.ORG

Power Quality

Edited by Andreas Eberhard

Published by InTech

Janeza Trdine 9, 51000 Rijeka, Croatia

Copyright © 2011 InTech

All chapters are Open Access articles distributed under the Creative Commons Non Commercial Share Alike Attribution 3.0 license, which permits to copy, distribute, transmit, and adapt the work in any medium, so long as the original work is properly cited. After this work has been published by InTech, authors have the right to republish it, in whole or part, in any publication of which they are the author, and to make other personal use of the work. Any republication, referencing or personal use of the work must explicitly identify the original source.

Statements and opinions expressed in the chapters are these of the individual contributors and not necessarily those of the editors or publisher. No responsibility is accepted for the accuracy of information contained in the published articles. The publisher assumes no responsibility for any damage or injury to persons or property arising out of the use of any materials, instructions, methods or ideas contained in the book.

Publishing Process Manager Ana Nikolic

Technical Editor Teodora Smiljanic

Cover Designer Martina Sirotic

Image Copyright TebNad, 2010. Used under license from Shutterstock.com

First published March, 2011

Printed in India

A free online edition of this book is available at www.intechopen.com

Additional hard copies can be obtained from orders@intechweb.org

Power Quality, Edited by Andreas Eberhard

p. cm.

ISBN 978-953-307-180-0

Calibration of High Voltage Transducers for Power Quality Measurements in Electric Networks

Hélio Tatizawa¹, Erasmo Silveira Neto², Geraldo Francisco Burani¹,
Antonio A.C. Arruda¹, Kleiber T. Soletto¹ and Nelson M. Matsuo¹

¹University of São Paulo

²Cia de Transmissão de Energia Elétrica Paulista – ISA CTEEP
Brazil

1. Introduction

The term power quality is, in general, closely related to the quality of the voltage. Considering the widespread presence of sensitive loads in the electric grid, and the increasing awareness of the consumers concerning the quality of the power supply, the control and measurement of power quality parameters regarding harmonics, interharmonics, sags, swells, and others are increasingly becoming much more important. Most of the necessary calibration procedures for power quality monitors and power quality analyzers are already defined in the international standards, mainly in the IEC 61000 series (IEC, 1995) and ANSI/IEEE Standards. This chapter presents results of a research which aimed to develop a methodology for the calibration of high voltage transducers for power quality measurements in high voltage networks, considering that such kind of procedures have not been established in the pertinent standards yet (Bradley et al., 1985; Seljeseth et al., 1998). In this research it is also considered that the conventional high voltage laboratory is not suitable for power quality tests. Thus, some improvements are needed regarding such matter. In this development, modelling and computer simulation using ATP – Alternative Transients Program (ATP, 1987) were used to assess both the frequency response of the test setup, and the design of the reactive compensation of the test circuit.

2. Test setup development

Capacitive voltage dividers (CVD) are commonly used for the measurement of power quality parameters in power systems networks (Dugan et al., 2004), thanks to their modularity and easy installation in transmission and distribution substation environment. Fig. 1 shows a typical installation at field, in a 345kV transmission substation. In this Fig. 1 the high voltage branch of the CVD is shown, composed of six 500pF modular capacitances, nominal voltage 50kV. Further to Fig. 2, all the capacitances of the high voltage branch (C1) are identical with nominal value of 500pF. For the measurement, the number of 500pF capacitances can be changed according to the expected voltage to be measured, in order to limit the voltage on the C2 capacitance of the secondary low voltage branch.

This paper shows the development of the test circuit for the calibration of voltage transducers, focused on measurements of power quality disturbances in power systems high voltage networks. This kind of development faces many levels of difficulties, considering that the generation of stabilized and well defined power quality disturbances, in the high voltage range (for example, over 1kV), for calibration purposes, requires the adaptation of the conventional high voltage laboratory equipment. Overall, the conventional high voltage laboratory is only equipped with high voltage sources for generating power frequency (60Hz or 50Hz) and impulse (atmospheric and switching) high voltage waveforms, used in dielectric tests of high voltage equipment insulation (IEC, 1994). For calibration of high voltage transducers used in power quality disturbances measurements, additional waveforms are necessary such as voltage harmonics, sags (or dips), swells, etc. Therefore, in order to achieve the calibration circuit, the test circuit components were defined as follows:



Fig. 1. Capacitive voltage divider (CVD) - installation for measurements in a 345kV substation.

- arbitrary waveform voltage source for generating sinusoidal waveforms, with low harmonic distortion, considering harmonic frequencies up to the 50th order (3000Hz), and generation of composite waveforms (fundamental frequency + harmonics), with enough power capacity for the calibration tests. In this research, a conventional commercial power quality generator was used for such purpose.

- a step-up high voltage test transformer, fed at the low voltage side by the arbitrary waveform voltage source, to produce in the high voltage side the waveforms generated by the source (considering composite waveforms and harmonics), with enough power required by the calibration tests. The option of generating high voltage waveforms in such way was motivated either by absence or by the non availability of high voltage sources for the waveforms required by the research in the calibration tests, mainly considering high voltage levels found in transmission systems, in the hundreds of kV range. The expected load for the test transformer during the calibration tests is supposed to be of capacitive nature, mainly capacitive voltage dividers (CVD) and capacitive voltage transformers (CVT). On the whole, CVTs present very high values of capacitance (few thousands of pF), thus becoming a very heavy load for the high voltage test transformer.
- Capacitive voltage dividers composed of 500pF modules, voltage 50kV.
- Power quality analyzer for the transducers calibrations. In this research, a class A (IEC, 2002) commercial power quality analyzer was used.

At the initial stage tests, a high voltage transformer with rated voltage 220V/100kV and rated power 10kVA was used. The test circuit is shown in Fig. 2.

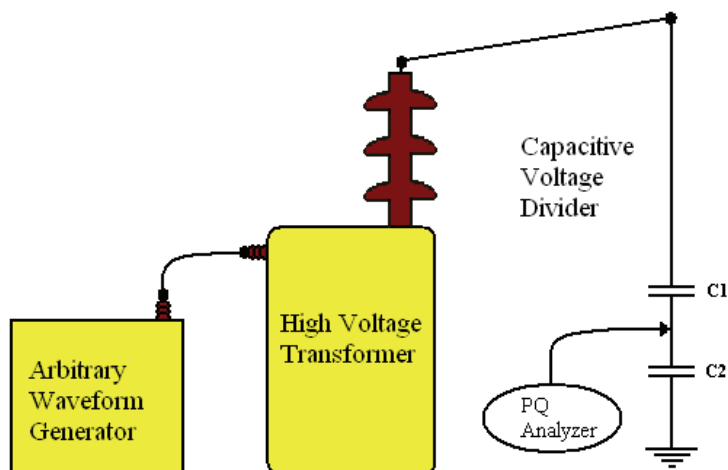

Fig. 2. Tests performed with the arbitrary waveform voltage source – test setup.

2.1 Electric model of the high voltage transformer

The option of using a high voltage transformer to generate high voltage for the calibration tests implies in introducing a series equivalent reactance of the transformer in the test circuit. This option was eventually necessary, considering the non availability of a commercial high voltage source with the capability of generating the required waveforms for the calibration tests. The series association (sum) of this leakage reactance with the load capacitances (CVD – Capacitive Voltage Dividers and CVT – Capacitive Voltage Transformers) results in a resonating (tuned) circuit for certain harmonic frequencies.

For the electrical modelling of the high voltage test transformer, the equivalent circuit was obtained by means of impedance voltage and no-load loss tests. The obtained equivalent circuit, for 60 Hz, is shown in Fig. 3.

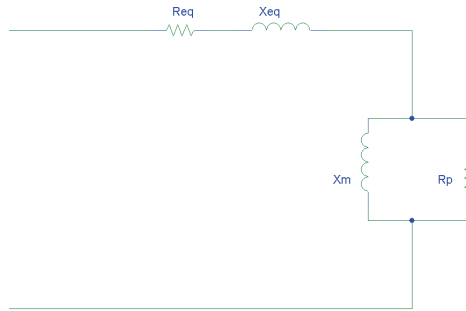

Fig. 3. Equivalent circuit of high voltage transformer where: R_{eq} – equivalent resistance, X_{eq} – equivalent leakage reactance, X_m – magnetizing reactance, R_p – equivalent no-load loss resistance.

Considering both the impedance voltage and no-load loss tests, the value of the equivalent circuit parameters are shown in Table 1.

Parameter	Values referred to low voltage side (Ω)	Values referred to high voltage side (Ω)
R_{eq} (Ω)	0,151	31,2k
X_{eq} (Ω)	0,673	139,0k
R_p (Ω)	322,7	66,7M
X_m (Ω)	116,3	24,0M

Table 1. Equivalent circuit of the high voltage test transformer

2.2 Electric model of the test setup

Considering the obtained values of the step-up test transformer (referred to the high voltage side) and CVD, the equivalent circuit of the test setup is shown in Fig. 4.

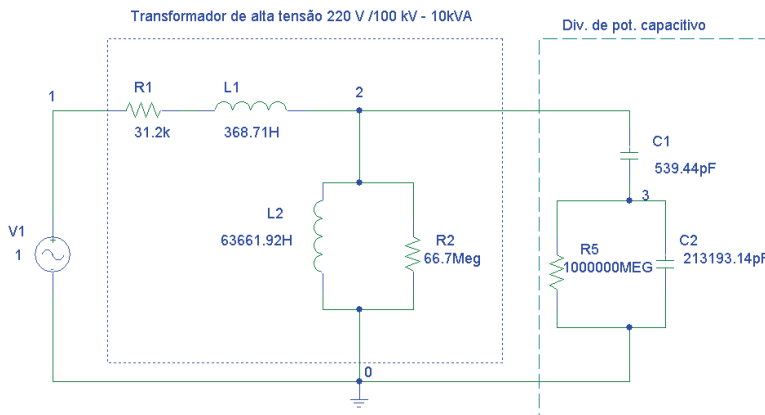

Fig. 4. Electric model of the test setup with step-up test transformer and capacitive voltage divider.

Obs.: Resistance R5 is included for a better numerical stability in computer simulations, without affecting overall results due to its very high value of $1.000.000M\Omega$.

2.3 Test setup modelling and computer simulation

Aiming to analyze the test circuit behavior under harmonic voltages, modelling and computer simulation were performed using ATP - Alternative Transients Program (ATP, 1987). For the simulations, the model of the test setup shown in Fig. 4 was used. The test setup frequency response, obtained with ATP program, is shown in Fig. 5. In such figure both transformer output voltage and CVD output voltage (multiplied by 100) are shown for each frequency. A resonant frequency can be seen at 350 Hz.

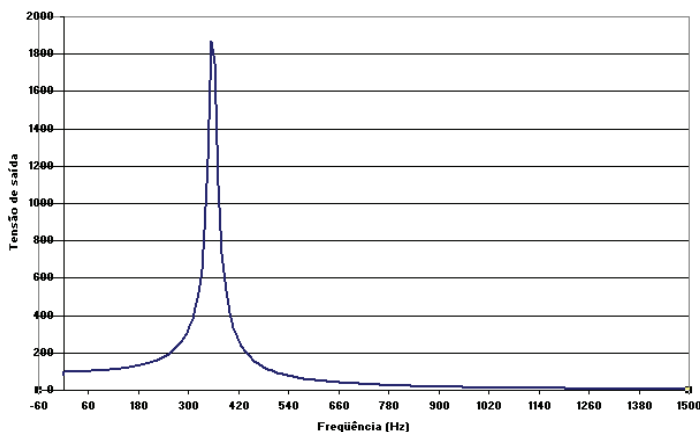

Fig. 5. Test circuit frequency response obtained with ATP program showing transformer high voltage output.

Computer simulation results showed a non flat frequency response of the test circuit, with a resonant frequency at 352Hz (near 5th harmonic). Experimental results of measurements made at the transformers low voltage side, using both a power quality analyzer and spectral analysis demonstrated results which are in accordance with what was previously found, with an amplifying effect at 5th harmonic, caused by the proximity with the resonating frequency.

2.4 Analysis of the circuit

Considering the test setup model, a simplified equivalent circuit is obtained by calculating the series and shunt association of impedances. This simplified circuit is shown in Fig. 6 and 7.

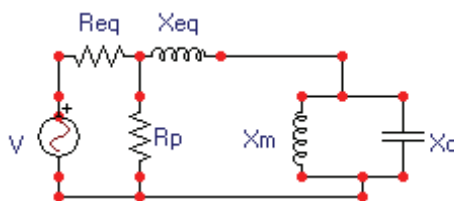

Fig. 6. Test circuit electrical model.

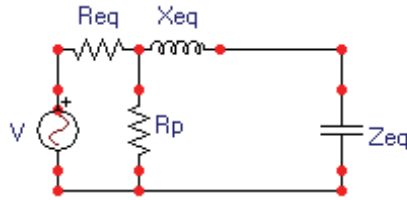

Fig. 7. Test circuit simplified electrical model.

Considering the equivalent circuit, the resonating frequency is caused by the series association of (step-up transformer leakage reactance) and (equivalent impedance of the shunt association of CVD and magnetizing reactance of transformer).

At resonating frequency:

$$\begin{aligned}
 X_{eq} &= Z_{eq} \\
 Z_{eq} &= X_m // X_c \\
 Z_{eq} &= \frac{X_m \cdot X_c}{X_m - X_c} \\
 X_{eq} &= \frac{X_m \cdot X_c}{X_m - X_c}
 \end{aligned} \tag{1}$$

Where X_m represents the magnetizing reactance of transformer and X_c responds for the capacitive reactance of CVD.

With:

$$\begin{aligned}
 X_{eq} &= j\omega L_{eq} \\
 X_c &= \frac{1}{j\omega C_{eq}} \\
 X_m &= j\omega L_m
 \end{aligned} \tag{2}$$

At resonating frequency:

$$\omega = \sqrt{\frac{1}{L_m C_{eq}} \left(\frac{L_m}{L_{eq}} - 1 \right)} \tag{3}$$

Where L_m is the magnetizing inductance of transformer and L_{eq} is the leakage inductance.

By applying the numerical values:

$$\omega = 2238,58 \text{ rd / s}$$

Therefore, the calculated resonating frequency $f = 356.28$ Hz shows good agreement with the computer simulation results.

2.5 Laboratory tests results – test setup development

Measurement results obtained with a power quality analyzer, and using an arbitrary waveform generator at the high voltage transformer input showed that this test setup can

generate high voltage harmonics presenting low harmonic distortion. Fig. 9 shows high voltage transformer output spectrum, when a 60Hz sinusoidal waveform is applied at input. The measurement was performed at the capacitive voltage divider low voltage branch, using a power quality analyzer. In Fig. 8, a low harmonic distortion can be seen, with very small values of higher order voltage harmonics.

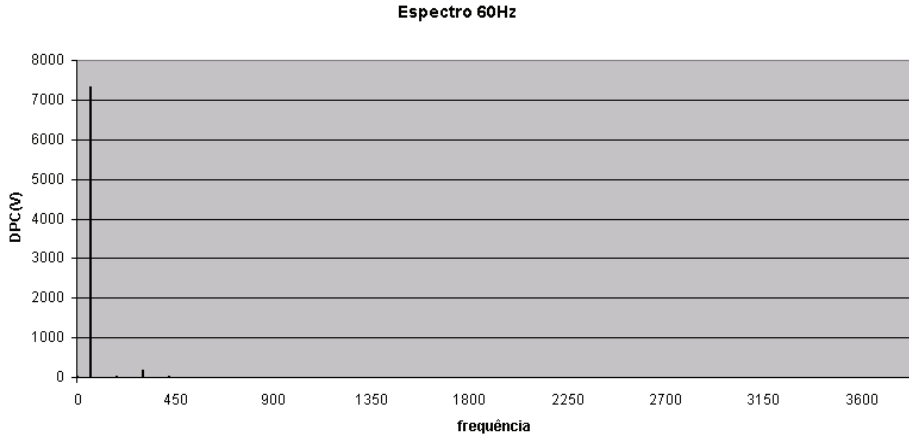

Fig. 8. Test transformer output voltage spectrum, with a 60Hz voltage applied at input.

Fig. 9 shows the high voltage transformer output, when the input arbitrary waveform generator is adjusted for composite waveform generation, with frequencies 60 Hz, 180Hz, 300Hz and 400Hz. The measurement was performed using the power quality analyzer applied to the CVD output.

Fig. 10 presents the output voltage spectrum of the high voltage transformer.

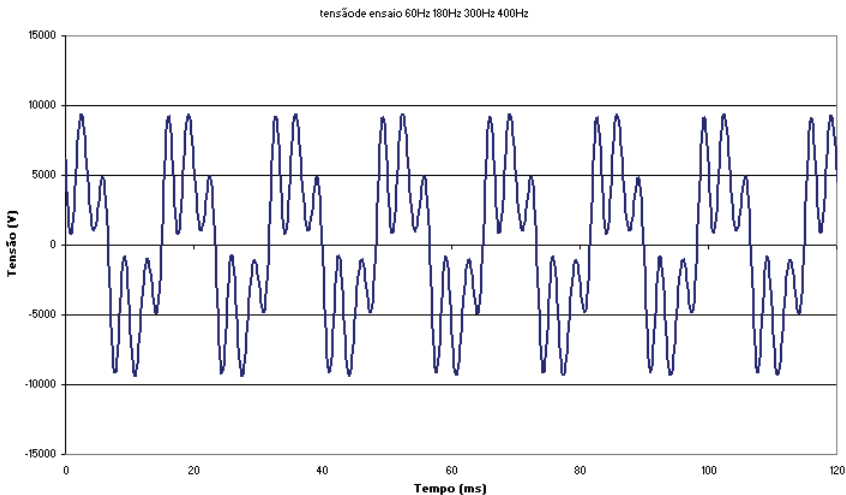

Fig. 9. Test transformer output voltage, for input voltage with 60 Hz, 180Hz, 300Hz and 400Hz harmonic components.

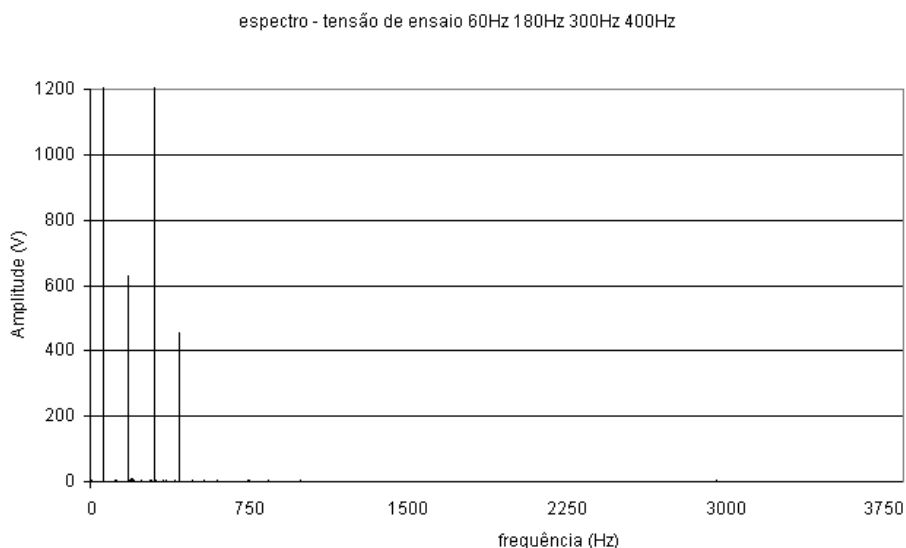

Fig. 10. Test transformer output voltage spectrum, for input voltage with 60 Hz, 180Hz, 300Hz and 400Hz harmonic components.

According to Fig. 10, at the transformer output, only harmonic components actually applied to the input were obtained (60Hz, 180Hz, 300Hz and 400Hz), showing the linear behavior of the transformer. Considering the voltages amplitudes for each harmonic frequency, they depend on the transformer ratio and frequency response of the test setup. In this research, alternatives to improve frequency response were studied, by applying passive components (resistances, capacitances and inductances) at the low voltage side of the test transformer. Such action aimed at generating fundamental and harmonic voltages (high voltages), without causing overflow of the voltage source (arbitrary waveform generator), with rated power 5kVA. Good results were obtained in such studies (see section 4).

2.6 Measurement of CVD capacitances

Capacitance and loss tangent values of the CVD components are of fundamental importance, considering their role in the transformation ratio and phase error during measurements. So, measurements were performed in the high voltage branch capacitances using the Schering Bridge method. It must be considered that in such method measurements are performed applying high voltages, with similar conditions found in actual measurements using CVD. Those capacitance measurements were performed with test voltages of 10kV and 30kV, and similar results were obtained for the capacitance and loss tangent measurements for both test voltages.

In actual conditions, the secondary branch capacitance of the CVD works under a voltage of about 200V (60Hz). For the measurement of that secondary branch capacitance, three methods, which are shown in Table 2, were used.

Measurement results in all three methods were very similar, showing a little influence of test voltage and frequency in the capacitances values.

Measurement method	Applied voltage during measurement (V)	Frequency (Hz)
Schering Bridge (Tettex)	200	60
Resonating Bridge (QuadTech)	1	1k
Volt-ampère Method	200	60

Table 2. Measurement of CVD secondary capacitance

3. Test setup for calibration of voltage transducers

Considering high voltage measurements at field, instrument transformers are commonly used for power frequency voltages. However, for using such transducers in power quality studies, a calibration in a broader frequency range is needed due to the various kinds of power quality disturbances. The capacitive voltage transformer (CVT) is a transducer which is normally found in transmission and distribution substations. Overall, a CVT presents a high capacitance (thousands of pF); therefore a technical difficulty for the test circuit implementation tends to arise.

This high capacitance together with low impedance may become a problem for the voltage source (an arbitrary waveform generator) to feed the test setup, considering its rating of 5kVA. For instance, a 4,000pF CVT, to be used in a 230kV power system, is a 27kVA load at rated voltage. Such load is above the rating of the arbitrary waveform generator with rated power of 5kVA. This difficulty is increased as long as there are higher order harmonics.

Fig. 11 shows the test setup for the calibration of a capacitive voltage transformer (CVT).

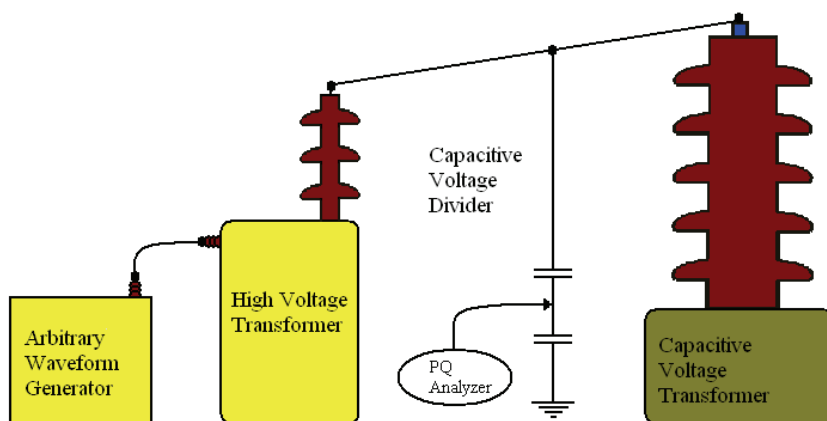

Fig. 11. Test setup for the calibration of a capacitive voltage transformer, with voltage source (arbitrary waveform generator), high voltage transformer, capacitive voltage divider (adopted as Reference Transducer) and test object (CVT).

Fig. 12 shows the electrical equivalent model of the test setup shown in Fig. 11

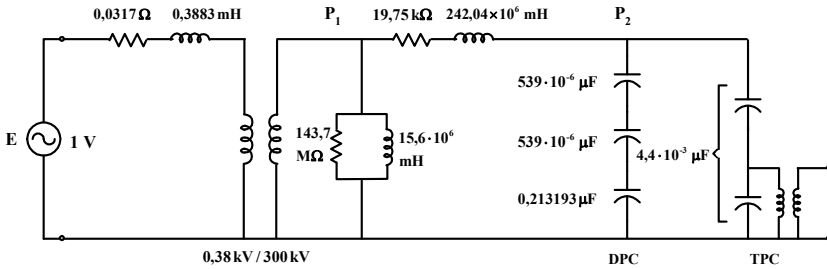

Fig. 12. Electric model of the test setup shown in Fig. 11, with voltage source (arbitrary waveform generator), high voltage transformer, capacitive voltage divider (adopted as Reference Transducer) and test object (CVT).

The test transformer used in this circuit is a 300kV, 70kVA step-up transformer, where the equivalent circuit, again, was obtained by means of no-load and impedance voltage tests. Computer simulation studies were performed, using Alternative Transients Program - ATP, considering a hypothetical voltage source (amplitude 1V) applied at the circuit's input.

Fig. 13 shows the frequency response curve of the circuit of Fig. 12, without reactive compensation.

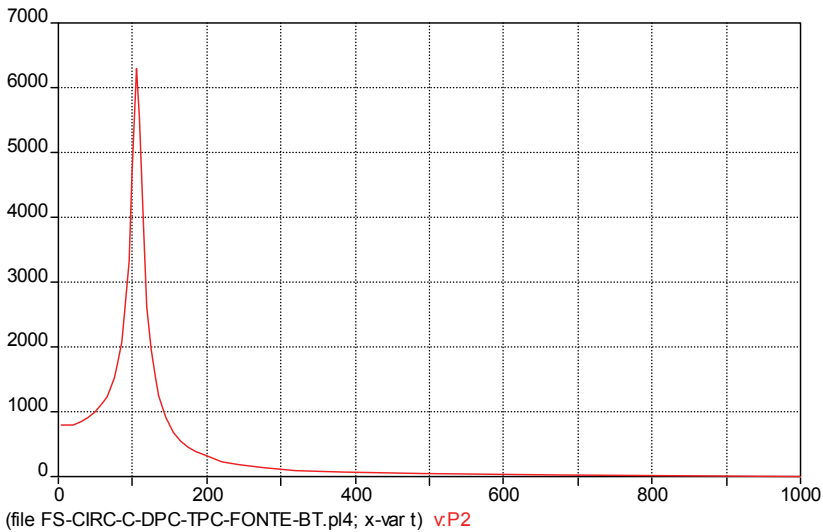

Fig. 13. Frequency response curve of the circuit shown in Fig. 12, without reactive compensation - Output voltage applied to the Capacitive Voltage Transformer (CVT)

The frequency response curve in Fig. 13 is similar to the one in Fig.5, showing a non flat frequency response of the test setup, with a resonant frequency at 125Hz.

Fig. 14 shows this same curve, presented in a log-log scale.

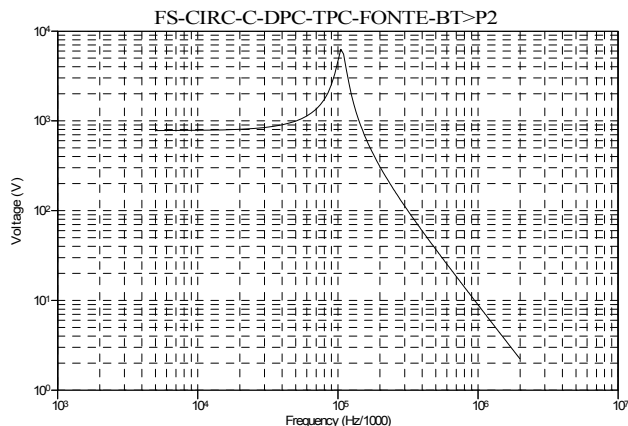

Fig. 14. Frequency response curve of the circuit shown in Fig. 12, without reactive compensation, presented in a log-log scale - Output voltage applied to the Capacitive Voltage Transformer (CVT).

Fig. 15 shows the voltage source electrical current output for each harmonic frequency. In this Fig., a resonant frequency can be seen at about 125Hz, showing a current peak at this frequency.

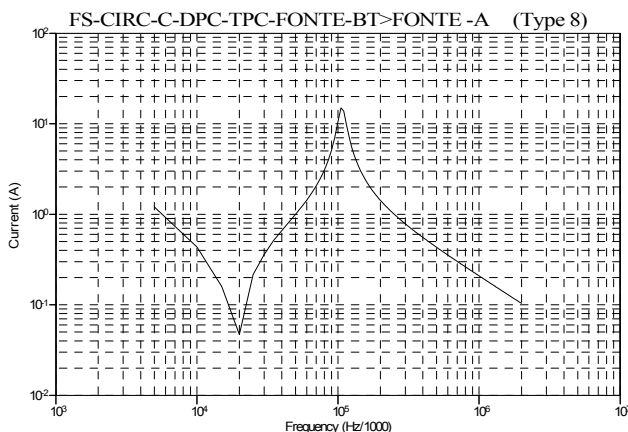

Fig. 15. Frequency response curve of the circuit shown in Fig. 12, without reactive compensation, presented in a log-log scale – Electrical current at voltage source output for each harmonic frequency.

Considering the frequency response curve shown in Fig. 15, high values of electrical current are to be expected at the arbitrary waveform generator output, showing the need for some kind of frequency dependent compensation to be provided. By means of computer simulation using the ATP program, many alternatives of reactive compensation circuits were studied, aiming to generate high values of output voltage applied to the Capacitive Voltage Transformer, and concomitantly, low values electrical currents at the voltage source output.

4. Test setup with shunt reactive compensation

In order to obtain the necessary high voltage waveforms for the calibration tests, additional studies were made, considering the use of passive components (resistances, inductances and capacitances), aiming at reactive compensation considering harmonic frequencies. Those studies were performed using Alternative Transients Program – ATP, considering a hypothetical voltage source (amplitude 1V) applied at the circuit input.

Those computer simulations aimed at evaluating the output voltage applied to the CVT for each harmonic frequency. Also, those studies analyzed the voltage output in many different situations, by applying resistances, capacitances and inductances at the high voltage and/or low voltage sides of the step-up transformer. Such action was done so as to improve the frequency response curve of the test circuit, and therefore obtain higher values of voltage output together with lower values of input electrical current in the test setup.

Fig. 16 shows the electric model of the test setup for the calibration of a 230kV CVT, capacitance 5,300pF, with reactive compensation provided by the shunt capacitance and shunt inductance. This reactive compensation is intended to obtain low intensity of electrical current at 60Hz and, simultaneously, high values of voltage for harmonic voltages applied to the CVT. The dimensioning of the shunt capacitance and inductance was performed with the aid of the ATP program computer simulation.

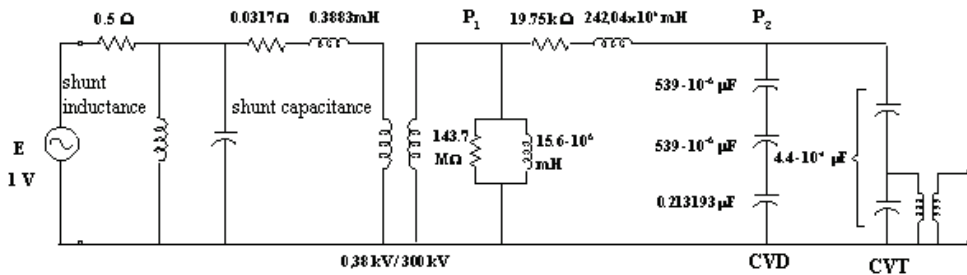

Fig. 16. Electric model of the test setup, for calibration of a 230kV CVT. On the left, it is shown the shunt capacitance and inductance, and the 0.5Ω resistance for reactive compensation.

CVT Capacitance (pF)	Frequency (Hz)	Shunt inductance (mH)	Shunt capacitance (μF)
5,300	120	0.35	15,000
	180	1.2	2,300
	300	1.2	650
	660	1.4	117

Table 3. Reactive compensation for each harmonic frequency, for 5,300pF CVT

In this test setup, the values of the shunt inductance and capacitance are adjusted for each harmonic frequency. For instance, for the calibration of the CVT in harmonic frequency of 300Hz (5th harmonic), a 1.5mH inductance and a 650μF capacitance are used. The 0.5 Ω resistance in series with the voltage source makes the frequency response curve smoother, simplifying the tuning of the shunt capacitance and inductance values for reactive

compensation. Table 3 shows values of reactive compensation for other harmonic frequencies, considering a 5,300pF - 230kV capacitive voltage transformer.

Figs. 17 and 18 show the frequency response of the test setup (without the 0.5Ω series resistance), with reactive compensation for 300Hz, for the test transformer voltage (high voltage side) and the voltage source output current, respectively.

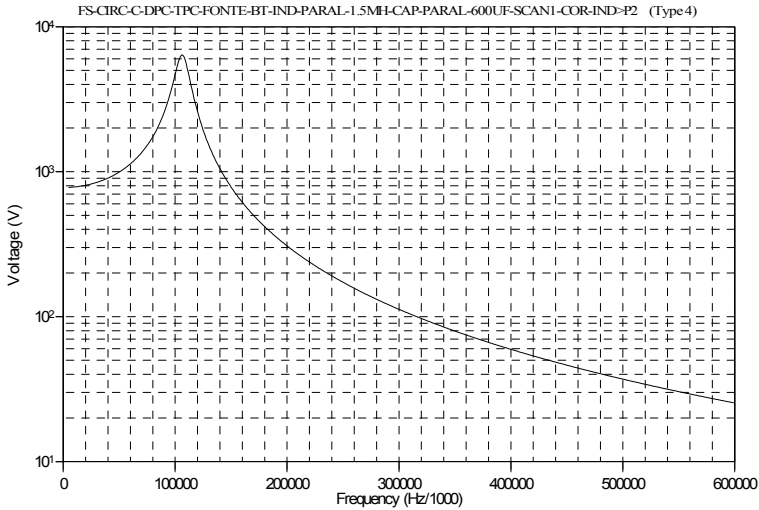

Fig. 17. Test setup frequency response, with reactive compensation for 300Hz, without the 0.5Ω series resistance. Test transformer output voltage (high voltage side).

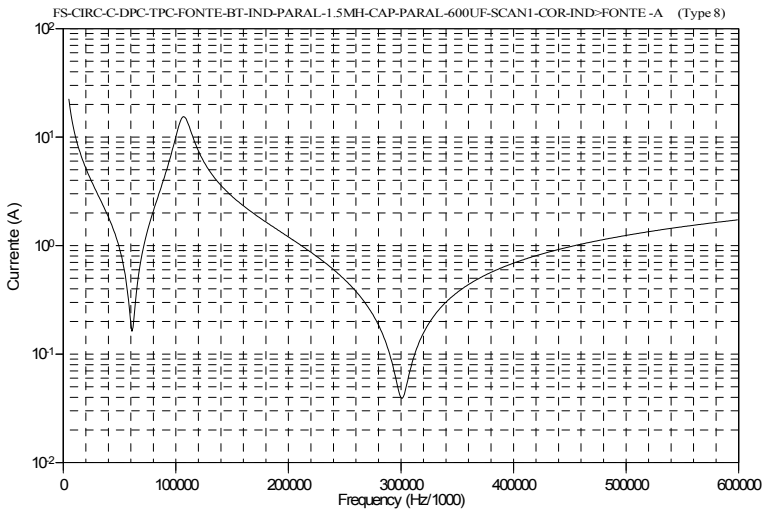

Fig. 18. Test setup frequency response, with reactive compensation for 300Hz, without the 0.5Ω series resistance. Voltage source (arbitrary waveform generator) output current.

Fig. 18 shows that at 300Hz, a minimum value of voltage source output current is obtained. Also, for 60Hz there is another minimum value, making this test setup suitable for applying, during the calibration tests, a composite waveform with a 60Hz and 300Hz voltage harmonic components.

Fig. 19 shows the voltage at the primary side of the step-up transformer, for each harmonic frequency. The primary side voltage remains stable, implying in stability of the arbitrary waveform generator voltage source output.

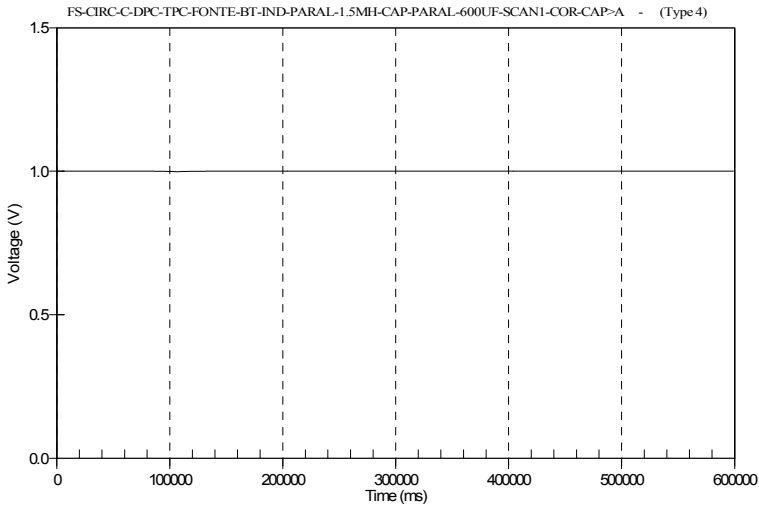

Fig. 19. Voltage at primary (low voltage side) of step-up transformer considering harmonic frequencies.

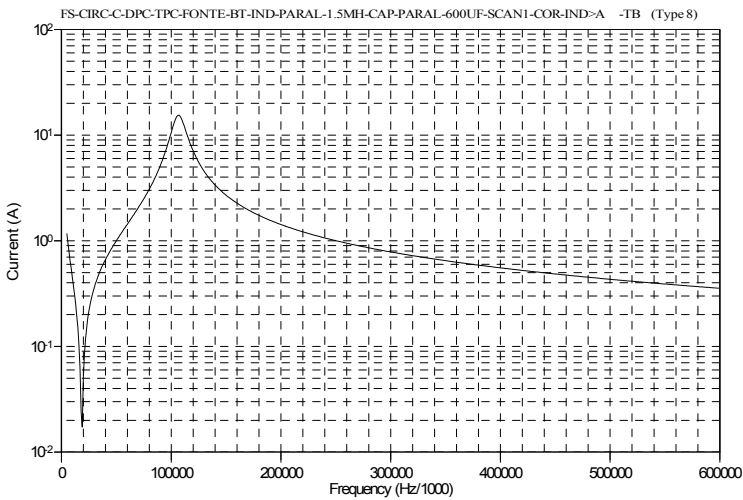

Fig. 20. Electrical current at primary (low voltage side) of step-up transformer.

Fig. 20 shows the electrical current at this same low voltage side of the step-up transformer. High values of electrical current (200A range at test voltage) are expected at 60Hz frequency for the transformer primary side.

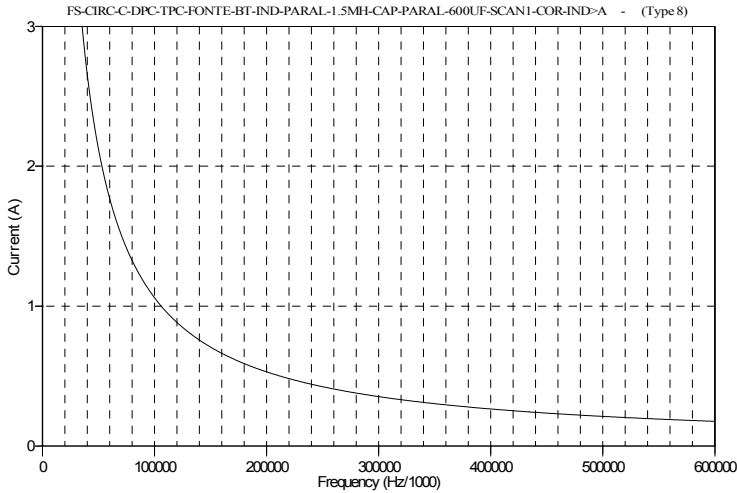

Fig. 21. Electrical current in the shunt inductance, at the primary side of the step-up transformer.

Fig. 21 shows the electrical current in the shunt inductance, at the primary side of the step-up transformer. High values (200A range at test voltage) of electrical current are expected at 60Hz frequency.

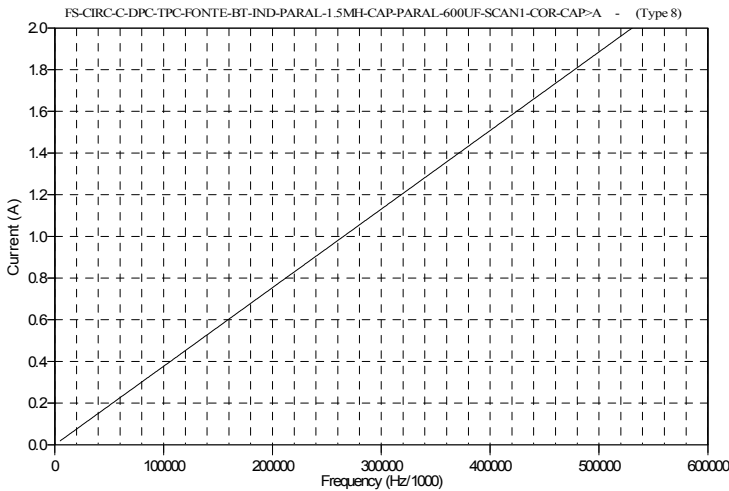

Fig. 22. Electrical current in the shunt capacitance, at the primary side of the step-up transformer.

Fig. 22 shows the electrical current in the shunt capacitance at the low voltage side of transformer.

4.1 Influence of the series resistance

Fig. 23 shows the test setup equivalent circuit, with series 0.5Ω resistance, shunt 1.5mH and $600\mu\text{F}$ capacitance for passive reactive compensation applied at the low voltage side of the step-up transformer.

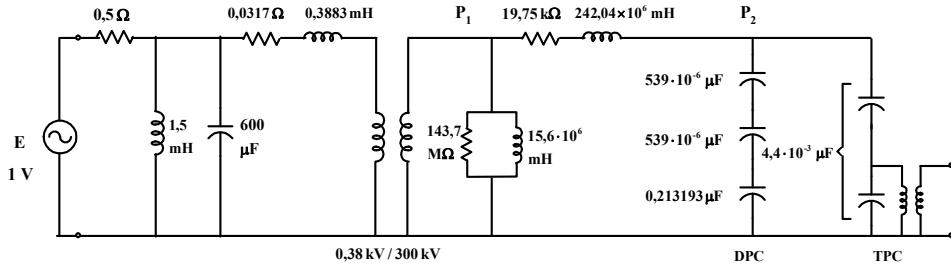

Fig. 23. Electric model of the test setup, with series 0.5Ω resistance, shunt 1.5mH and $600\mu\text{F}$ capacitance for passive reactive compensation applied at the low voltage side of the step-up transformer.

Fig. 24 shows output voltage of the test setup, applied to CVT.

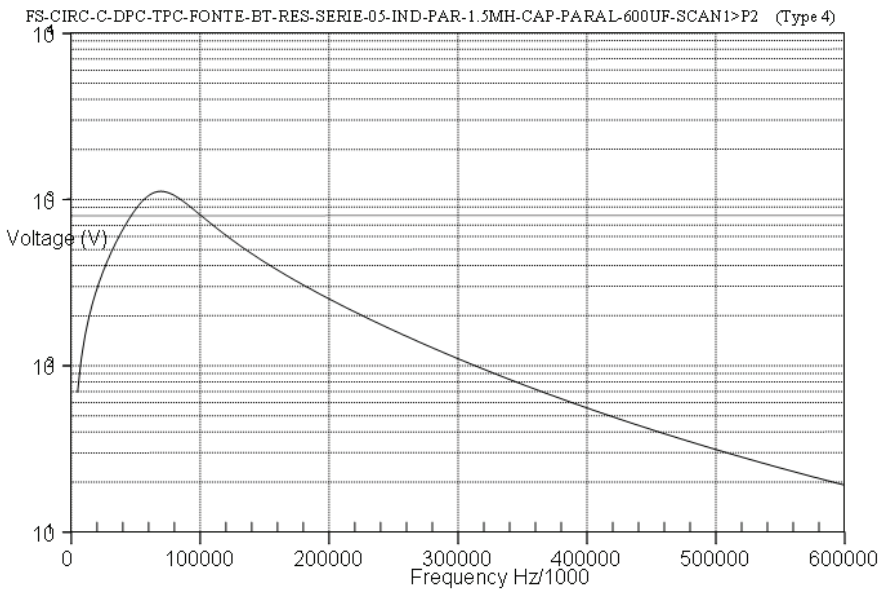

Fig. 24. Output voltage of test setup, applied to CVT, with series 0.5Ω resistance, shunt 1.5mH and $600\mu\text{F}$ capacitance for passive reactive compensation.

Fig. 25 shows the voltage source output current, with series 0.5Ω resistance, shunt 1.5mH and $600\mu\text{F}$ capacitance for passive reactive compensation.

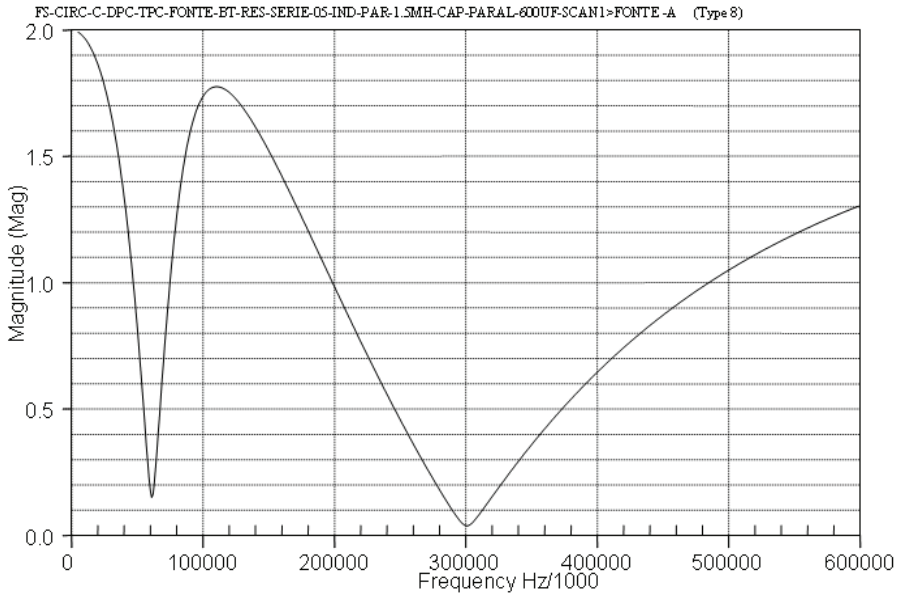

Fig. 25. Voltage source output current, with series 0.5Ω resistance, shunt 1.5mH and $600\mu\text{F}$ capacitance for passive reactive compensation.

Figs. 24 and 25 show that the presence of the series 0.5Ω resistance provides an smoothing effect on the peaks of the frequency response curves (compare with Figs. 17 and 18) at the resonant frequencies. This feature is advantageous, making the tuning of the test circuit easier, in the sense that the specification and adjustment of the values of the capacitances and inductances used for reactive compensation are less strict, without the necessity of being too precise concerning the design specification of such values.

5. Conclusions

Considering the obtained experimental results, it was possible to assure the effectiveness of this test setup for generating sinusoidal high voltage waveforms, keeping under control, at low values, the total harmonic distortion. Also, with this test setup, composite waveforms were produced, at high voltage level, keeping the harmonic distortion under control, with the aid of reactive compensation. Additionally, with reactive compensation, it was possible to keep under acceptable low values the output current of voltage source, considering 60Hz and other higher order harmonic current components. This test setup also showed the feasibility of testing, at high voltage levels, test objects with high capacitance (capacitive voltage transformers with thousands of pF capacitance), for 60Hz and higher order harmonics, using reactive compensation. For testing CVT's with higher capacitance, or for to generate harmonics of higher frequency, the use of a higher output power arbitrary

waveforms generator with may become necessary. This solution is feasible, but may imply in higher costs.

6. References

- ATP - Alternative transients program - Rule Book, Bonneville Power Administration, 1987.
- Bradley DA, Bodger PS, Hyland PR, Harmonic response tests of voltage transducers for the New Zealand power systems, IEEE T-PAS, vol PAS-104, n° 7, 1985.
- Dugan, RC, McGranaghan, MF, Santoso, S, Beaty, HW, Electrical power systems quality, 2nd Edition, McGraw-Hill, 2004.
- IEC - International Electrotechnical Commission, IEC 60060-1 Standard, High voltage test techniques 1994.
- IEC - International Electrotechnical Commission, IEC 61000 Standard series, Electromagnetic compatibility (EMC) - (various parts), 1995.
- IEC - International Electrotechnical Commission, IEC 61000-4-7 Standard, Electromagnetic compatibility (EMC) - Test and measurement techniques - General guide on harmonics and interharmonics measurements and interpretation, for power supply systems and equipment connected thereto 2° edition 2002.
- Seljeseth H, Saethre EA, Ohnstad T, Voltage transformer frequency response. Measuring harmonics in Norwegian 300kV and 132kV power systems. Proceedings IEEE 8° International Conference on Harmonics and Quality of Power ICQHP '98, Athens, 1998.